

GT AUDIO GT500/X10

GT500/X10

Offering meaningful power and some great controls at a very affordable price point, as well as a lower current demand, this class D amplifier is ideal for running smaller and lighter subwoofers with clarity and detail.

DETAILED TECHNICAL DATA

Power Output@40hm:	220WRMSX1 (@1%Thd)
Power Output@20hm:	380WRMSX1 (@1%Thd)
Power Output@10hm:	500WRMSX1 (@1%Thd)
Minimum Load:	10hm
Input Level:	150Mv>3V
Frequency Response:	10Hz>190Hz
LPF:	40Hz>180Hz
Subsonic Filter:	0Hz>50Hz
Minimum Power Supply:	60Amps
Operational Power Range:	9>16Volts
Maximum Earth Impedance:	0.020hms
EQ Boost:	0>12dB
EQ Boost Frequency:	30Hz>80Hz
Amplifier Technology:	Class D
Power Terminal:	4AWG
Speaker Terminal:	12AWG

TECHNICAL DRAWING

GT AUDIO

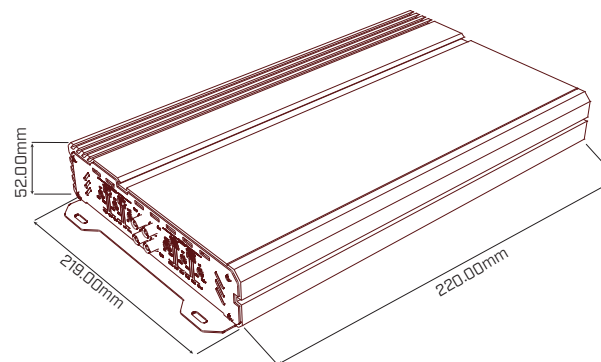

Total Height:	52mm
Total Length:	220mm
Total Depth:	219mm
Approx Weight:	2.01Kg

TEAM TIPS

GT AUDIO

- ⦿ NEVER insert or remove ANY wires from the amplifier whilst it is powered up. The output speaker terminals have DC half rail on them. This means that if a tool shorts to the case the amplifier will be immediately damaged, even if no music is playing. This damage is NOT warrantable.
- ⦿ The most common cause of amplifier failure is a poor earth. Use the right sized cable, with properly crimped terminals, fastened to bare chassis metal using a bolt. Anything less can result in NON warrantable damage.
- ⦿ USE THE SUBSONIC FILTER - By eliminating frequencies below your audible output you can add significant performance to the system whilst building a margin of safety.
- ⦿ Be sure to allow for any EQ boost you will apply when you set the amplifier gains. Remember, you are boosting to even the bass RESPONSE, not to extract power that does not exist!